



2010 Rules, Regulations & Specifications BANGERS

Contents

| | |
|--|----|
| 1. THE FORMULA | 2 |
| 2. WHO CAN RACE..... | 2 |
| 3. WHAT TO DO NEXT | 2 |
| 4. ELIGIBLE CARS..... | 2 |
| 5. INITIAL PREPARATIONS..... | 3 |
| 6. PERSONAL SAFETY | 3 |
| 7. SAFETY EQUIPMENT..... | 4 |
| 7.1 CRASH HELMET..... | 4 |
| 7.2 RACING OVERALLS/GLOVES | 4 |
| 7.3 A NECK BRACE | 4 |
| 7.4 WET WEATHER CLOTHING | 4 |
| 7.5 1kg FIRE EXTINGUISHER..... | 4 |
| 7.6 DRIVERS SEAT WITH HEAD RESTRAINT | 4 |
| 7.7 SAFETY HARNESS | 4 |
| 8. VIOLATIONS | 5 |
| 9. GENERAL RULES OF RACING..... | 6 |
| 10. DEMOLITION - TYPE EVENTS..... | 6 |
| 12. BODYWORK | 7 |
| 13. ENGINES..... | 8 |
| 14. GEARBOX..... | 8 |
| 15. WHEELS & TYRES..... | 8 |
| 16. EXHAUSTS | 9 |
| 17. COOLING SYSTEM | 9 |
| 18. BRAKES..... | 9 |
| 19. FUEL SYSTEM..... | 9 |
| 20. BATTERIES & THE ELECTRICAL SYSTEM..... | 9 |
| 21. MIRRORS..... | 10 |
| 22. PAINTWORK..... | 10 |
| 23. SUN VISOR..... | 10 |
| 24. FIN PLATES | 10 |
| 25. DOOR NUMBERS | 10 |
| 26. SPECIFICATION AND RULE CHANGES..... | 10 |

1. THE FORMULA

This formula is designed to encourage new drivers to our circuits, to enjoy the atmosphere & thrills of driving on an oval, without the substantial financial investment. It also gives the opportunity to race to those drivers who cannot give the commitment necessary to compete at the very high level of all our other Formulas. The Formula should appeal to all drivers: from complete novice, who may be concerned about contact (they can display a black & white cross on the back of their car until they are confident to race without it), & the more experienced driver, who can use **light contact** allowed after 3 laps have been completed, to make his/her way through the traffic to the finishing flag.

The object of the racing is to complete the specified number of laps in the shortest time without contact with the other cars on the track for the first 3 laps. You may push a car from behind, or spin a car either way but there is no following in (you must not be on the back or side of a car as it hits the fence). If at any time the racing is felt to be "processional or roddy" the Starting Marshall will wave a blue flag & then drivers must not overtake another car without attempting to spin the car out. However, you must not deliberately follow another car into the safety fence (whether from the rear, front or side), as this will be deemed forcible fencing & carry penalties or a ban which could be for life.

Racing is in a clockwise direction on a clearly defined circuit with a separate infield. Any wheels passing over the demarcation lines or entering on to the grassed infield areas will mean that the driver will be penalised.

2. WHO CAN RACE

Formerly know as Bombers, this formula is especially designed to encourage new drivers to Stadium Racing and to enjoy the atmosphere and excitement of driving without a large financial investment, or for drivers who feel they cannot give the commitment required to compete at a very high level in the other various formulas available. Drivers who have achieved high success in any other senior type formula over the past five years cannot compete in the Banger formula. All licence applications will be reviewed by the Promoter and it must be understood that applications may be refused if it is considered that the prospective driver is too experienced for this entry level formula.

Day licenses are available at a cost of £20 per meeting – a temporary license form must be completed in full.

3. WHAT TO DO NEXT

1. Check through the fixture list for the Banger fixtures and select a meeting or meetings.
2. Contact the Stockcar Office for a booking-in form which you must complete. Details about payment can be discussed with the Administrator.
3. Return the form to the Racing Administrator as soon as possible, as bookings are on a first come first served basis.
4. When the form has been processed you will be placed on to the booking system.
5. On arrival at the Stadium you must first book in at the pit office and pay any fees applicable.
6. You must then get the car Scrutineered and obtain the Passed Scrutineering Sticker which has to be displayed in a prominent position on the car.
7. Ensure you are familiar with the raceway flags and the rules of racing, as you are now ready to race and will come under all the Rules & Regulations, similar to all the other formulae.

4. ELIGIBLE CARS

1. Any right-hand 2 wheel drive saloon, hatchback or estate car with a steel body with an engine size not exceeding 1600cc, with either carburettors or Multi Point Injection **or Diesel**. Exceptions to this rule are the following vehicles which are not permitted: Vauxhall Vectra, Ford Mondeo, Cortina, Capri, Granadas, Mini, BMW's, Nissan Bluebird and any type of Van.



5. INITIAL PREPARATIONS

1. Remove all exterior mouldings, screen glass, lamps and handles.
2. Remove all interior trim, the dash & passenger seating.
3. Remove the fuel tank, spare wheel carrier & tow bar if fitted.
4. Remove all obsolete wiring and interior debris from the car.
5. Both steel & plastic front & rear bumpers must be removed.
6. Read & familiarise yourself with the Banger Rules & Regulations for preparing the race car.

6. PERSONAL SAFETY

Drivers are advised that under Health & Safety, they are responsible for their own and their Mechanic's actions. Promoters have had complaints made about Registered Drivers & also Mechanics, consuming large amounts of alcohol at meetings, which could effect their judgement or be detrimental to their health, when medical attention has to be administered by Paramedics, St Johns or Hospital Staff.

Should an incident occur that proves fatal on the raceway and you are involved, it is likely that the Police will want interview you. **If you drive, don't drink!** Scrutineers and Officials will report to the Clerk of the Course, anybody they believe is under the influence of Drink or Drugs. Drivers who are thought to be under the influence, may be breathalysed.

Flags as used by the Starting Marshall & Trackside Safety Staff.

- Waved Green Flag – Go, the race has started.
- Waved Red Flag – Stop racing, slow down and stop immediately.
- Chequered Flag – The race winner has crossed the line, continue to race until the Red Flag is shown.
- Held Yellow Flag – Beware, you are approaching a hazard on the track, continue to race with caution.
- Waved Yellow – Slow down to 15mph, hold your position, **and do not** overtake any other cars. The pace car is entering the circuit to control the pace until the raceway is clear to race.
- A Blue Flag – The race has become processional, you may not pass another driver without attempting to spin them out.
- Black cross on a White board – You have committed an infringement and may be penalised in the results.

- Waved Black Flag - You are disqualified, pull off the track immediately.

Drivers are also reminded that they should line up on the grid with their engines switched off in the correct points order, unless told otherwise.

7. SAFETY EQUIPMENT

7.1 CRASH HELMET

A Crash Helmet having a minimum specification as detailed by the British Oval Racing Safety Executive (BORSE). Visors or Goggles must be worn for racing or practice. Tinted visors are not advisable. Polycarbonate (Plastic) helmets of any type are not permitted. It should be noted that from 2010 the Snell SA2000 and the BS6658 Type A will be obsolete.

| Helmet minimum specification : (as detailed by BORSE) | | |
|---|---|-----------------------------------|
| FIA | | 8860- 2004 |
| British Standards Institute | 1 | BS6658 - 85 Type A |
| Great Britain | 2 | BS6658 - 85 Type A FR |
| The Snell Foundation | 1 | SA2000 - SA2005 |
| USA: | 2 | SF1 Foundation 31.1A or 31.2A |
| The European E22 Standard | 1 | With Serial Number starting 05 |
| : | 2 | Fibre Glass or Fibre Glass/KEVLAR |

7.2 RACING OVERALLS/GLOVES

You must wear Fire retardant, clean, un-torn and brightly coloured Racing Overalls that are made of a fire retardant material and are clearly marked fireproof. Mechanics are also required to wear clean overalls and will not be permitted on to the track without them being on, when instructed to do so. It is mandatory to wear fire retardant gloves also clearly marked fireproof.

7.3 A NECK BRACE is recommended but not compulsory, so to is a spine support.

7.4 WET WEATHER CLOTHING is also recommended and must be worn in addition to, and **not** instead of the racing overalls.

7.5 1kg FIRE EXTINGUISHER

You must have a 1kg dry powder Fire Extinguisher with a sight gauge, either fitted in a tube with a spring over the top fitted in the car or easily accessible on the race transporter. The Green CO2 type of extinguisher is not allowed.

7.6 DRIVERS SEAT WITH HEAD RESTRAINT

You must have a Driving Seat with a head restraint and this may be of a competition type. The seat should occupy its original position where possible and be suitably supported at shoulder height and on both of the sides and back, with a suitable framework or seat stiffener's.

Additional wrap around seat support at shoulder height.

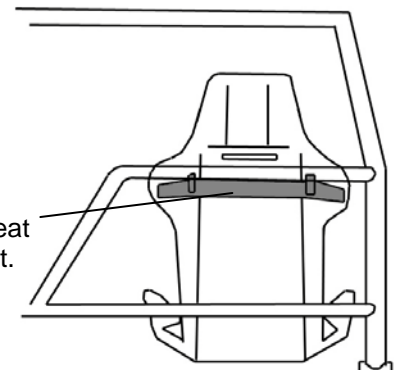

7.7 SAFETY HARNESS

The lap belt/straps and crotch straps should not pass over the sides of the seat, but through it, in order to wrap and hold the pelvic region over the greatest possible surface.

It is mandatory to have a **4 point separate fixing** Safety harness with 2" shoulder straps, the lap straps can be either 2" or 3" in width. All seatbelt connection points must be visible and no belts pass through any firewall.

Following research made by leading safety harness manufacturers, information has been made available

with regard to the best way to fit your safety harness; this will further ensure your safety. Please study the diagrams to ensure your safety harness is fitted correctly.

The lap belt crossing should be below the anterior-superior iliac spines (bony part of the hip). Under no circumstances should it be worn over the region of the abdomen.

Lap belt/straps **must terminate vertically downwards**, and not forwards or rearwards of the hip joint.

Lap straps should terminate symmetrically about the wearer on either side of the seat, about 20" (500mm) apart. The distance between the seating surface and the anchorage point should be kept to a minimum to prevent submarining. The location of the crotch strap mounting should be to the rear of the driver.

Fig.1 shows the location for the tail straps, which should be horizontal to 20° below horizontal, and as close to the shoulder as is practical for optimum restraint.

Only safety belts comprising of separate shoulder, lap, and sub- straps will be permitted.

The sub-strap must be used at all times, and all belts must connect to the quick release buckle. The abdominal strap fixing point must be on the chassis, roll cage, or floor (for vehicles with no chassis), either side of the driver.

The shoulder straps must be supported at shoulder height. NASCAR type buckles must be fitted with lever on the **right** side of the driver. It is advisable to fit a secondary means of detent to prevent overall sleeves accidentally unhooking the buckle during racing. A small section of tube grip **elasticated** bandage, slid over the hooked buckle, serves the purpose.

Special attention must be paid to the condition of seat belt fixings once fitted. Information is available, from your Promotion, on the correct procedure to follow when fitting seat belts. *Remember - your life depends on them, and belts, once involved in a severe accident, should be discarded and replaced.*

Over the years, we have had many unnecessary injuries due to badly fitted seats. They frequently occur in Non-contact Formulas, when perhaps a driver believes it is more unlikely that he will be involved in a serious crash, and he also believes that, if he is involved in a collision, the impact on his car will be from the front. However, this is often not the case. It is therefore, imperative that you ensure your seat is really well supported, especially where the shoulder straps go through. You must also ensure that your seat cannot move sideways.

The safety of your seat will be judged by the Scrutineer's and you will only be permitted to race when they are satisfied that you will be as safe as possible in any event.

8. VIOLATIONS

1. When referring to the engine, gearbox, final drive, mechanical or construction Rules & Regulations, the principle will always be: *Unless permission is specifically granted to make*

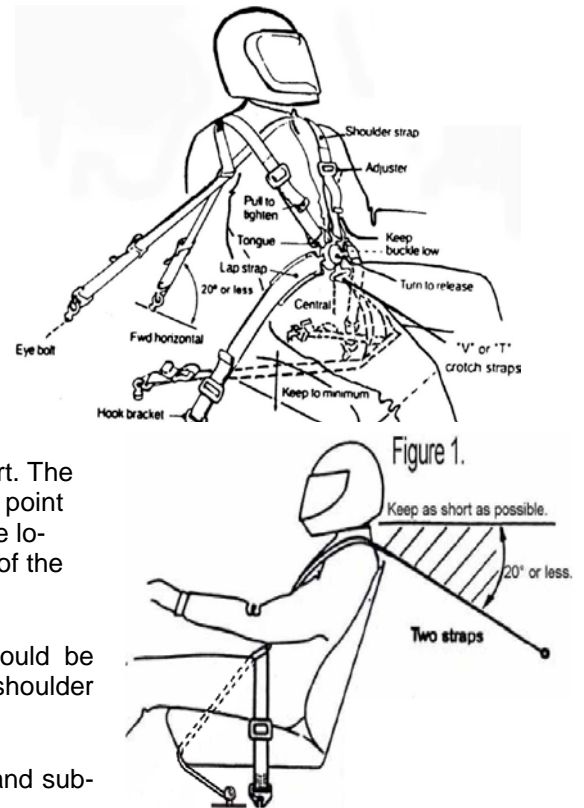

modifications (or any variation) nothing may be done to alter or change the Standard Parts in any way.

2. It is the responsibility of the Driver to prove to the Promotion that the part is legal, by way of written proof of where the part originated. This must be undertaken within 7 days, otherwise the item in question will be deemed illegal, resulting in immediate suspension from racing & referral for disciplinary action. **Unless the rules say you can do it, you cannot do it!**
3. Presentation of a Vehicle for Scrutineering is a declaration by the entrant that the vehicle is eligible for that event.
4. Car engines & fuel will be checked on a random basis. Violations or refusal to allow an engine check will result in an immediate suspension of all racing facilities.
5. All Car and Engine Specifications will be taken from either the manufacturers Technical Specifications or the Technical Service Data books as published by Glass's Guide.
6. Should a discrepancy occur between the Specifications then the Promotion will exercise its judgement, and that decision will be final.
7. Clarification on any one item may be sought from the Promoter.
8. Each driver is permitted one car per meeting & each car is permitted one driver per meeting.

9. GENERAL RULES OF RACING

1. There is no contact allowed between any cars on the circuit for the first 3 laps. The Starting Marshall usually waves a green flag after the completion of the three laps to inform you that light contact can occur.
2. Drivers apprehensive about contact can display in the rear window aperture a black cross on a white back ground, size of the display plate is 305mm or 12" square, to signify to other drivers that they must not make contact with your car during racing.
3. The Clerk of the Course has at his discretion the right to remove the Black cross from you, when he thinks you are confident to race with the others.
4. You must line up in your grid positions with the engine switched off.
5. Grid positions will be allocated on a first come first served basis on track. Race winners will start at the back of the grid for the rest of the meeting. If it is a points series meeting then the top 4 of the points series will start from the back of the grid.

10. DEMOLITION - TYPE EVENTS

The following rules apply to any race where the nature of the event is to win by stopping the opposition. Demolition Derby Rules may only be used when the staging promoter declares (by way of a drivers briefing, letter, or notice on the programme) that these rules apply

1. Attacking from the opposite directions permitted, providing the attack is from the outside of the track i.e. the fence side.
2. You may wait for a car or attack any part of the car except for the driver's area. This area is defined as being from the centre of the OSF wheel to the centre of the of the OSR door.

11. ROLL BAR

1. A Steel "H frame" or Hoop, made out of box or tube with a minimum size of 50mm or 2" or a 100mm or 4" maximum size, must be constructed behind the driving seat as close to the "B posts" as possible, to support the roof area & for protection on any side impact. The "H frame" feet, top & bottom, must have plates attached to them so that the feet can be bolted, by a minimum of 2 bolts per foot, on to the floor and roof.
2. The "H frame" fixing bolts for the feet have a minimum diameter of 8mm.
3. The Roll Bar frame must have a minimum of 2 *straight cross bars*, one at shoulder height to support the seat and the second much lower towards the floor, to act as a side impact brace. The cross bars must have end plates attached to them with a maximum size of 127mm or 5" square. The end plates may be extendable, but they must be welded or bolted to the frame, with no other extensions going forward or backwards. However, it is permitted if the Roll Bar is positioned slightly behind the "B posts", to have forward facing extensions that bolt through the "B posts" & then on to the end plates of the "H frame".
4. It is recommended that whenever possible to bolt the end plate to the door plate.
5. Safety belts, fuel tank, battery & fire extinguisher may be fitted securely to the "H frame".
6. It is recommended that any part of the cage coming in to contact with the driver is padded.

12. BODYWORK

Doors

1. The Drivers door is only part on the car that can be welded & it must be tack welded shut and a piece of box or tube can be welded to the lower window aperture. No other welding is permitted anywhere else on the car apart from the sun roof plate.
2. All the other doors *must* be fastened, you can use strips of metal, the strips must be no longer than 400mm or 15¾" in length, by 60mm or 2½" in width. Max four bolts can be used to attach each strip and the minimum size of the bolts/studding is 8mm in diameter & the maximum is 12mm diameter. Seat belt webbing can be used instead of Metal strips or the doors can be fixed with 12mm bolts directly through the Panels.
3. The tops of the door frames may also be tied with seat belt webbing, but you can still fit the door strips. Do not weld these other doors.

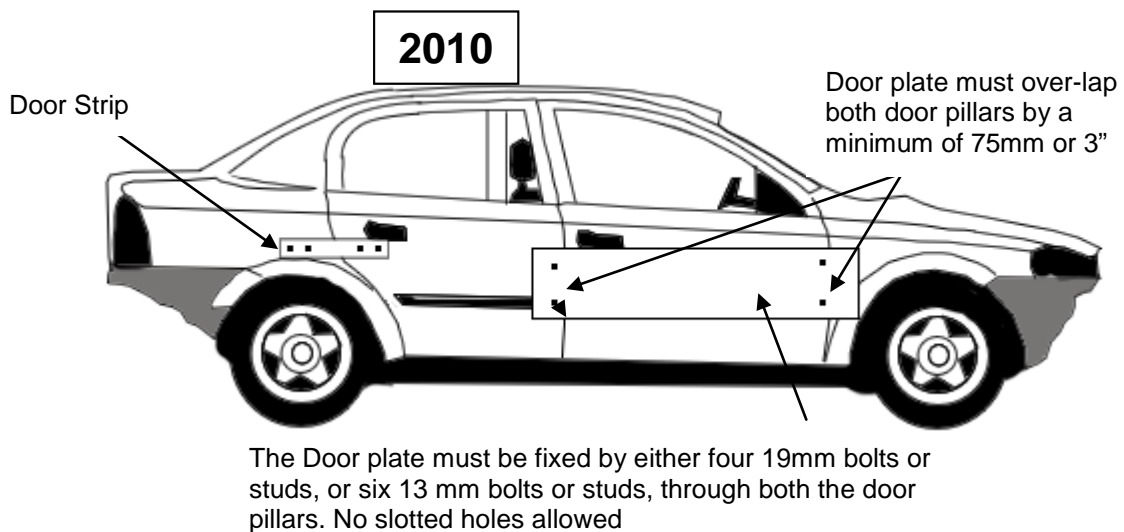
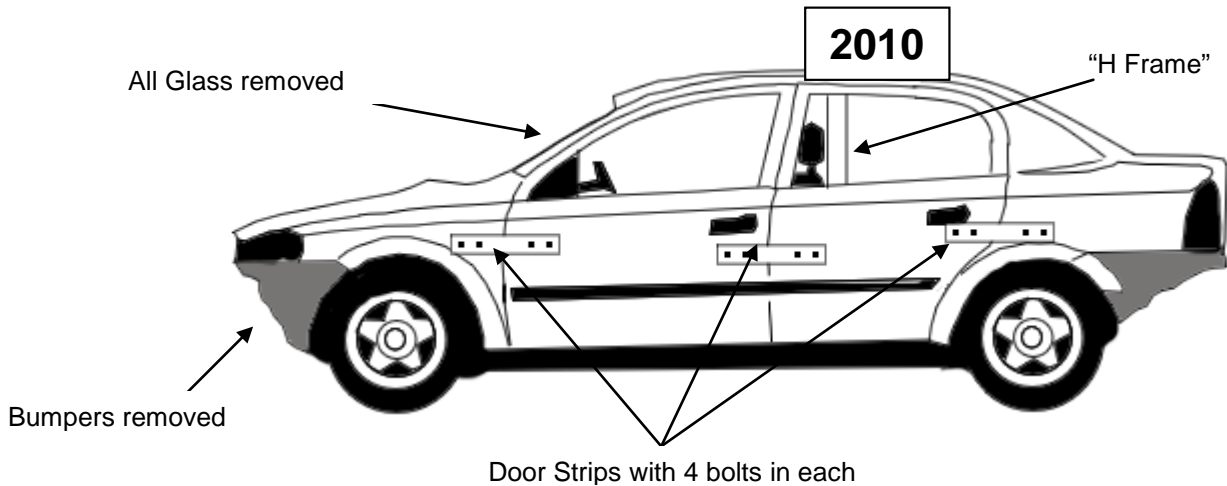

4. A driver's door plate must be fitted & overlap the door pillars by a minimum of 3".
NB. No trench plates are permitted.
5. The plate must be a minimum of 10mm or 3/8", to a maximum of 19mm or 3/4" in thickness.
6. Its depth must be no less then 254mm or 10" & no more then 305mm or 12".
7. The plate must be fixed by either four 19mm fixings or six 8mm fixings, through the door pillars with large washers on the inside.
8. The door plate holes must not be slotted.
9. An additional piece of angle iron or box section, not exceeding 76mm or 3" in its width and of any gauge, may be welded horizontally along the length of the door plate. The ends of this horizontal section must have the ends tapered or cut at an angle so as to prevent getting tangled up in rubbing situations. Any bolt fixings must not protrude this section of metal, they must be flush.

Front & Rear Bumpers

All bumpers plastic or steel must be removed. No tow bars must be left on the car.

Front Wings

The lower part of the wing may be trimmed level to where with the top of where the bumper was.

Bonnet Fixings

1. Bonnets may be removable but must be securely fixed front and back with bonnet locking pins of some form. If bolts are used a maximum thread size of 16mm, with maximum size of washer 4" or 4", i.e. **NO LARGE BANGER BOLTS BUT SHUTTERING BOLTS (DAGGY BARS) MAYBE USED**. No crush tubes allowed. Bolts must go through inner flitch or slam panel i.e. not through chassis. A maximum of 4 bolts may be used.

Triangular corner plates or straps may be used to secure the rear of the bonnet by bolting or welding (1/8" thick). Plates or straps must be placed no further than 12" across or down from the back edge and side of the bonnet. In this case you may only use two bolts at the front.

Sun Roofs

1. The glass must be removed and replaced with a piece of metal of a maximum thickness of 2mm, overlapping the aperture all the way round by 100mm or 4". The plate can be either welded or bolted in place. The fixing of this panel will have to meet scrutineering approval.

Aerofoils, Wings & Spoilers

1. No aerofoils / wings or spoilers are permitted unless they are fitted as standard.

Grills

1. These must be removed.

Engine Mounts

1. Engine mounts must be original and not welded. Except in Cavaliers/Astras where the front alloy may be replaced, but must remain in its' original position.

13. ENGINES

1. The engine must remain as it was produced in its standard form.
2. The air filter may be removed or replaced.
3. The carburettor body & Venturi's must not be altered or modified from the standard design.
4. Multi point injection can be used, but you may also remove the injection system and replace it with the previous carburettor set up **or Diesel**.

14. GEARBOX

1. The Transmission must be kept as produced for the model in its standard form.
2. You may not lock the differential.

15. WHEELS & TYRES.

1. All four wheels must be of the same diameter.
2. All wheel fixings must be in place.
3. All wheel weights & hub caps must be removed
4. Any standard road wheel steel or alloy up to a width of 6".
5. No Weller rims unless it's an FSO.
6. Only conventional tyres with a maximum tread depth of 6mm. Tyres must read <60 on durometer at any time.
7. Tyre Gaiters are permitted from January 1st 2009.
8. You are not allowed to do the following:

Use racing tyres. ~~50/55 low profile tyres~~, Mud & Snow tyres, Alpine tyres, Nobby or any type of competition tyre, Town & Country tyres, 7.3 Avon Turbo Speeds, Yokohama's, Colway

Competition tyres, Tread cut tyres, Tyre with the markings erased or National Bangers remould tyres.

Decisions on tyres will be at Scrutineer's discretion.

16. EXHAUSTS

1. An exhaust silencer must be fitted and reduce noise. It does not have to be the original manufacturers system.
2. No competition type systems are allowed.
3. Extra fittings are permitted.
4. Ineffective or systems that become insecure while racing will require you to pull off the circuit, as you will be excluded from the results & get a black flag.

17. COOLING SYSTEM

1. Radiators are free & may be moved to any position in the engine bay.
2. Electric cooling fans may be wired through a separate switch.

18. BRAKES

1. The *standard* manufacturers system must be used & work on all 4 wheels.
2. The handbrake must also be operational.

19. FUEL SYSTEM

1. The tank must be metal & have a maximum capacity of 9 litres. *No converted fire extinguishers are allowed.*
2. The fuel tank may be fitted to the "H frame" or behind the driver in the passenger area.
3. Fuel caps must be of a metal screw type, no push fit types are allowed
4. The fuel outlet must be from the top of the tank.
5. The tank must have a positive means of fixing.
6. A breather pipe must be fitted which should incorporate a one – way valve, with the pipe terminating below the tank so as to prevent spillage if inverted.
7. All fuel lines must be of good quality rubber or be metal covered, no rigid metal piping is allowed.
8. Only roadside fuel can be used **Petrol or Diesel**. No additives are allowed.
9. If an electric pump is fitted a cut off switch must be in close proximity of the driver.
10. Multi point injection can be used with a return back to the tank or a t-piece fitted in the fuel line between the fuel tank and the fuel pump but the electrical isolation switch (cut off switch) must be fitted in the N/S/R window area of the B post, for easy access of Safety Marshalls
11. You may also remove the Single or Multi-point injection system and replace it with a conventional carburettor if it's available from the manufacturers range. If you have doubts about the legality of the change, please phone the Stockcar Office for confirmation.

20. BATTERIES & THE ELECTRICAL SYSTEM

1. The Battery (~~only one battery is allowed & it must be similar in size to the original one that was fitted as standard~~) must be securely fixed & covered with a rot proof material, if it is not of the sealed cell type.
2. The batteries must be in a battery box.
3. The batteries must be a minimum of 152mm or 6" away from the fuel tank.
4. No seatbelt straps must interfere or come into contact with the battery.
5. A battery master switch must be fitted in the rear left-hand window and clearly marked "ON-OFF" or have an electrical danger decal. The cut-off switch must break the earth connection lead.
6. A self-starter motor must be fitted & working at all times.

21. MIRRORS

1. The Interior mirror may be fitted.
2. Door or Exterior mirror may be used but it must not protrude beyond the extreme body/chassis width of the vehicle.
3. Maximum mirror size is 152 x 100mm or 6"x4" and if glass, it must be covered in a clear plastic film to stop the glass fragmenting.

22. PAINTWORK

1. The external appearance of the car must look bright & professional at all times; drivers of scruffy looking cars will be told to improve their appearance & may not be allowed to race.
2. A maximum of two cars may be painted in team colours or painted to look similar, unless it is required by the Promoter for a particular team event.
3. Sign writing must be professional and be approved by the Promoter.

23. SUN VISOR

1. *A Sun visor 165mm or 6" in depth may be fitted with your name upon it.*

24. FIN PLATES

1. Fin plates must be fitted above the roof line but they should not be larger than 305mm or 12" by 559mm or 22" wide.
2. Fin plate numbers must be 229mm or 9" high by 38mm or 1½" in width, black numbers on a white background. Please ensure they are correct.

25. DOOR NUMBERS

1. The drivers racing number must appear on both sides of the car. The numbers should be 406mm or 16" high x 50mm or 2" wide, on a contrasting background, which must extend a minimum of 50mm or 2" beyond the numbers.
2. Your racing number must also be displayed on your bonnet facing the control box. The numbers should be 406mm or 16" high x 50mm or 2" wide, on a contrasting background.

.26. SPECIFICATION AND RULE CHANGES

The Promotion may at any time make amendments to the Specifications for the following reasons:

- In the interests of Safety
- Reduce costs for the driver
- In areas that are detrimental to the future of the formula
- If an unnecessary advantage has been deemed.

Current registered drivers will be notified automatically of any changes.